

Homework Day 8 - Cumulative Review of this unit

Show ALL work for the following problems! Use separate paper, if needed.

- 1) If $AC = 34$, $AB = 16$, find $\sin A$, $\cos A$, and $\tan A$.

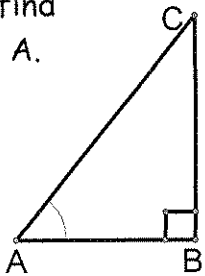

- 2) Solve the triangle given $m\angle A = 24^\circ$, $b = 10$, and $m\angle C = 90^\circ$.

- 3) A surveyor is measuring the distance across a small lake. He has set up his transit on one side of the lake 130 feet from a piling that is directly across from a pier on the other side of the lake. From his transit, the angle between the piling and the pier is 55° . What is the distance between the piling and the pier to the nearest foot?

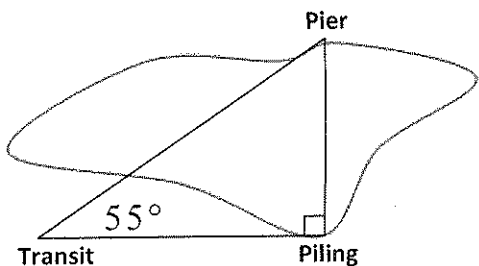

- 4) A surveyor standing 55 meters from the base of a building measures the angle to the top of the building and finds it to be 37° . How tall is the building?

For #5-8, solve the triangle. Round lengths to the nearest tenth and angle measures to the nearest degree.

5) $m\angle B = 47^\circ$, $m\angle C = 100^\circ$, $b = 20$

6) $m\angle B = 63^\circ$, $a = 12$, $c = 8$

7) $m\angle A = 35^\circ$, $a = 10$, $b = 13$.

8) $a = 5$, $b = 7$, $c = 10$

9) A building 240 feet tall casts a 30 foot long shadow. If a person stands at the end of the shadow and looks up to the top of the building, what is the angle of the person's eyes to the top of the building (to the nearest hundredth of a degree)? (Assume the person's eyes are 4 feet above ground level.)

10) Find the area of the triangle given $m\angle A = 48^\circ$, $b = 20$ feet, $c = 40$ feet.

Day 9 Homework

Solve each of the following trigonometric equations.

1) $\sin x - \frac{1}{2} = 0$

2) $2 \cos x - \sqrt{3} = 0$

3) $4 \sin x + 3 = 3 \sin x + 2$

4) $2 \sin x \cos x = \cos x$

5) $3 \tan x = 3$

6) $2 \cos x + 1 = 2$

7) $\sin x \cos x \tan x + \sin x \cos x = 0$

8) $2 \cos x \left(\cos x + \frac{1}{2} \right) = 0$

Solve each of the following trigonometric equations.

1) $\sin 3x = \frac{\sqrt{3}}{2}$

2) $\cos^2 x = 1$

3) $\sin 2x = 0$

4) $\sin 4x = -\frac{1}{2}$

5) $\tan 2x = \sqrt{3}$

6) $\sin^2 x - 0.25 = 0$

7) $\tan x + \sqrt{3} = 0$

8) $\sin \frac{1}{2}x = -\frac{\sqrt{3}}{2}$

*This part of the homework requires internet access.

Go to this website below and answer the questions: <http://www.geogebra.org/en/upload/files/riehl/sincostan2.html>

Sine, Cosine and Tangent Functions

Use the sliders to change the "a", "b", "h", and "k". Watch the equation change as the graph changes. Show and hide each graph. Grab points A, B and C to move them along the graph. Then answer the questions at the bottom of this screen.

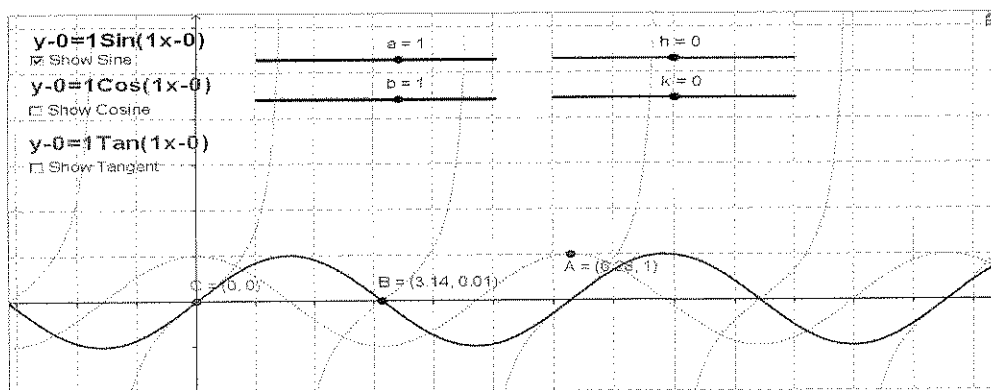

Answer these questions using terms such as domain, amplitude, period, x-intercepts and frequency.

1. How does the Sine and Cosine graphs change as "a" increases? As "a" decreases?
2. How does the Sine and Cosine graphs change as "b" increases? As "b" decreases?
3. What happens to the Sine and Cosine graphs when "a" goes from positive to negative?
4. How does the Tangent graph change as "a" increases? As "a" decreases?
5. How does the Tangent graph change as "b" increases? As "b" decreases?
6. What happens to the Tangent graph change when "a" goes from positive to negative?
7. Why does the Tangent graph drop off the bottom of the screen and reappear on the top?
8. What does the "h" variable do to the graphs (be specific)?
9. What does the "k" variable do to the graphs (be specific)?

Homework Day 11

For each function, find the amplitude, period, and midline then graph one cycle. Remember to label your axis!

1. $y = 3\cos(\theta)$

Amp. = _____

Per. = _____

Midline: _____

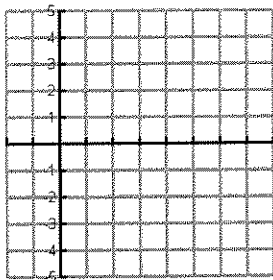

2. $y = -2\sin(\theta)$

Amp. = _____

Per. = _____

Midline: _____

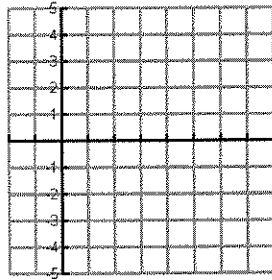

3. $y = 2\cos(2\theta) + 1$

Amp. = _____

Per. = _____

Midline: _____

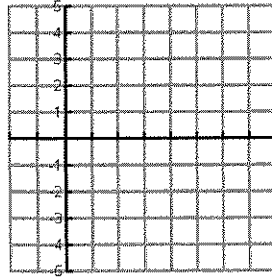

4. $y = \sin(3\theta) - 2$

Amp. = _____

Per. = _____

Midline: _____

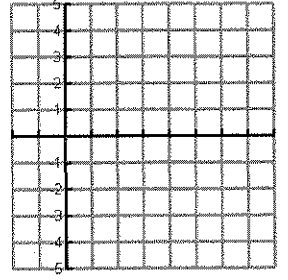

Solve $\triangle ABC$ given the following information. Show ALL work. Use separate paper, if needed.

5. $m\angle A = 40^\circ$, $m\angle C = 23^\circ$, and $b = 12$.

6. $a = 15$, $b = 18$, $c = 20$

7. $m\angle A = 75^\circ$, $a = 51$, and $b = 71$.

8. $c = 49$, $b = 40$, $m\angle A = 53^\circ$

9. For the following graph, identify:

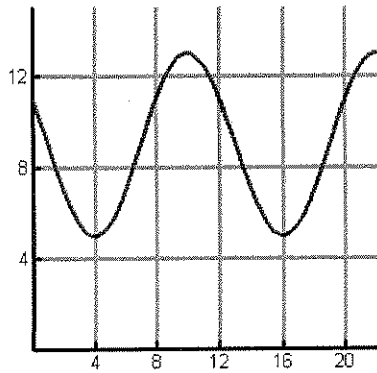

Amplitude: _____

Period: _____

Midline: _____

10. Jane has a 25 ft. ladder. If she leans it against a building, the angle of elevation is 65 degrees. How high up the building will the top of the ladder be?

11. A dog chased a cat up a tree. The cat is 12 feet up the tree. The angle of depression from the cat to the dog is 32 degrees. How far is the dog from the tree?

For problems #12-20, classify each triangle by its angles and sides.

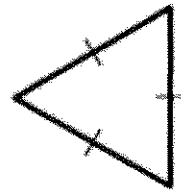
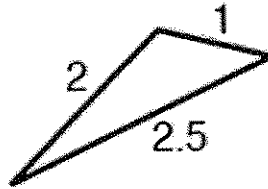
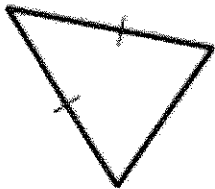

12. _____

13. _____

14. _____

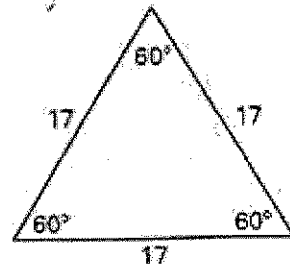
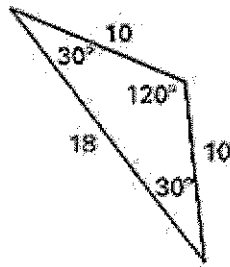
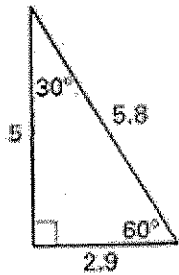

15. _____

16. _____

17. _____

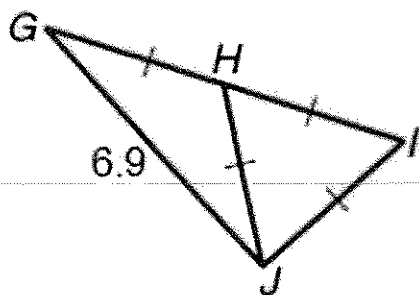

18. $\triangle GHJ$ _____

19. $\triangle IHJ$ _____

20. $\triangle GIJ$ _____

Day 12 Homework

Graph the following functions over two periods, one in the positive direction and one in the negative directions. Label the axes appropriately.

1. $y = 3\cos(x)$

Amplitude: _____

Midline: _____

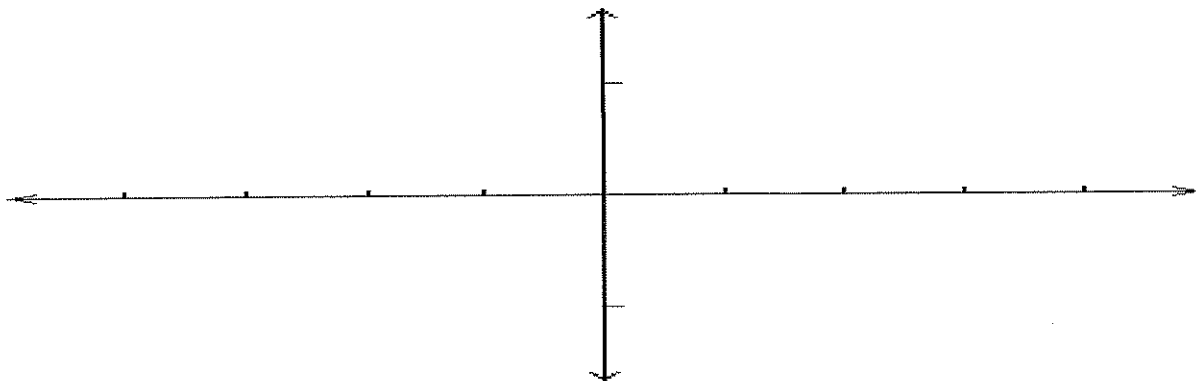

2. $y = 4\sin(x)$

Amplitude: _____

Midline: _____

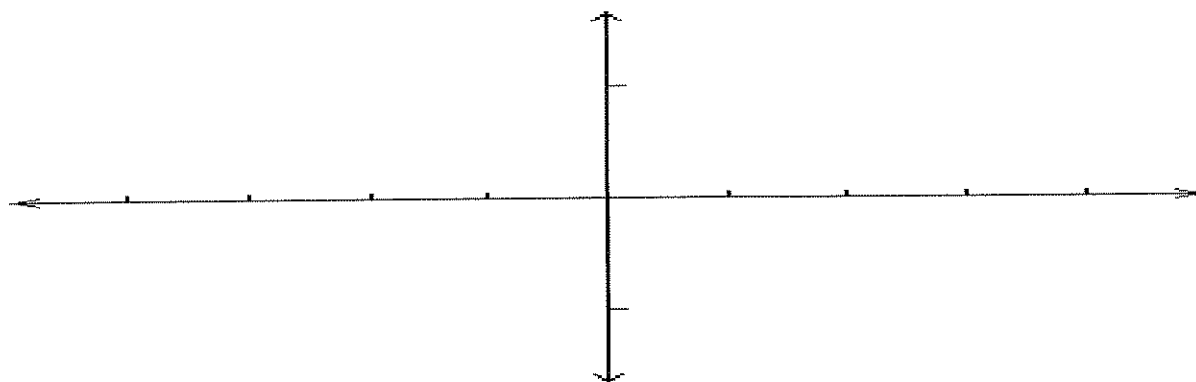

3. $y = -2\cos(x)$

Amplitude: _____

Midline: _____

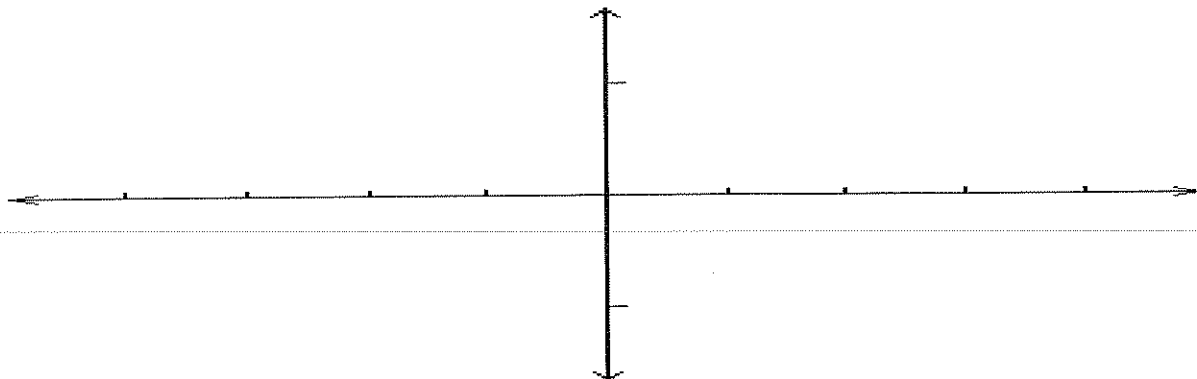

Graph each of the following trigonometric functions over the interval shown.

1) $y = \sin 3\theta$

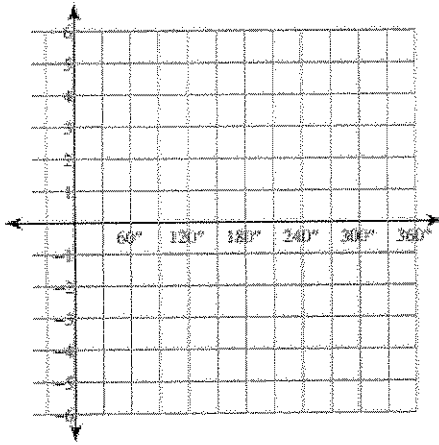

2) $y = 4\cos 3\theta$

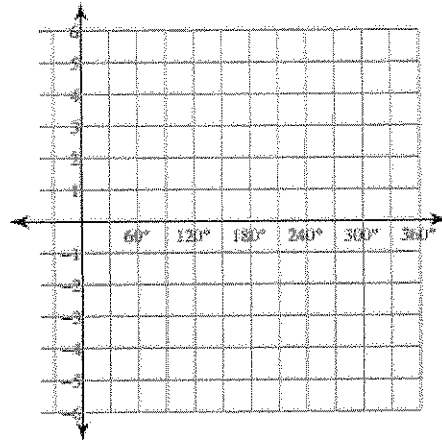

3) $y = 2\sin \frac{\theta}{3}$

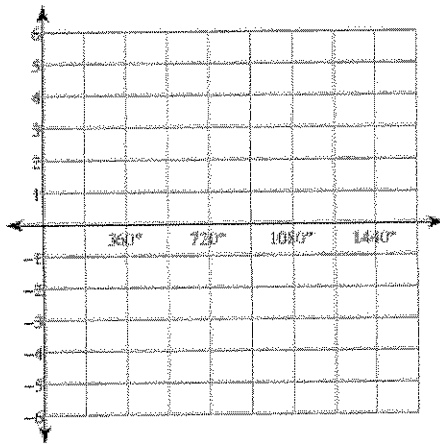

4) $y = \tan 2\theta$

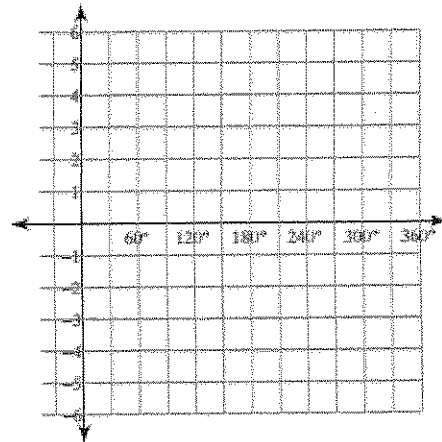

5) $y = 3\cos \frac{\theta}{2}$

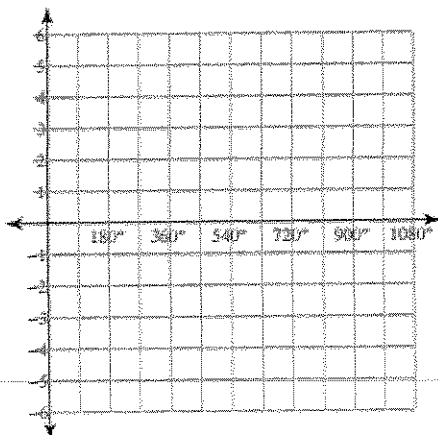

6) $y = \frac{1}{2}\tan \theta$

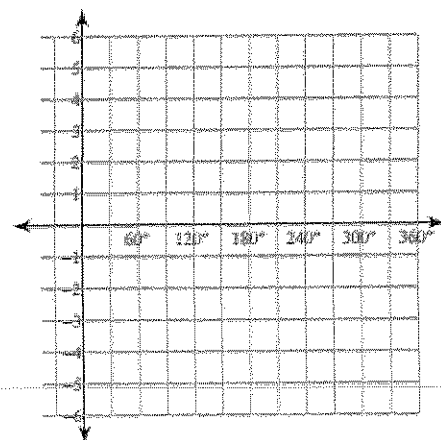

Homework Day 13

Graph the following functions over two periods, one in the positive direction and one in the negative direction. Label the axes appropriately.

1. $y = -3 \cos(2x)$ Amplitude: _____

2. $y = \sin(4x) + 1$ Amplitude: _____

Midline: _____ Period: _____

Midline: _____ Period: _____

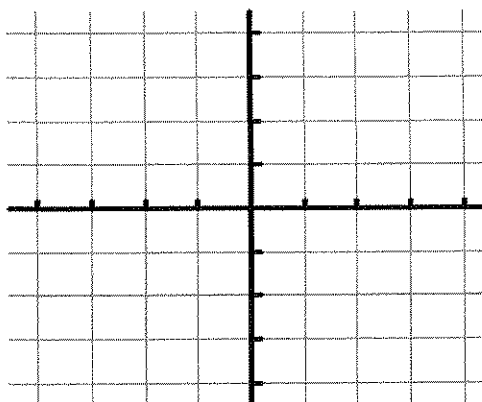
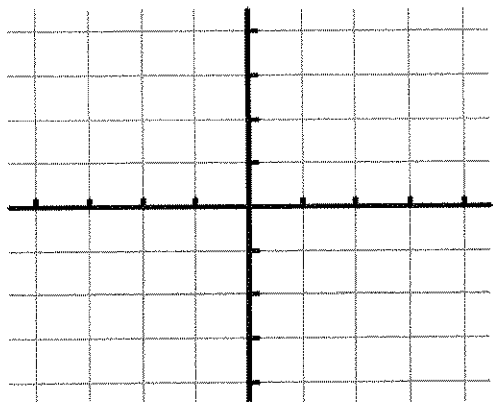

3. $y = 2 \cos(1/3x)$ Amplitude: _____

4. $y = -2 \sin(3x) - 1$ Amplitude: _____

Midline: _____ Period: _____

Midline: _____ Period: _____

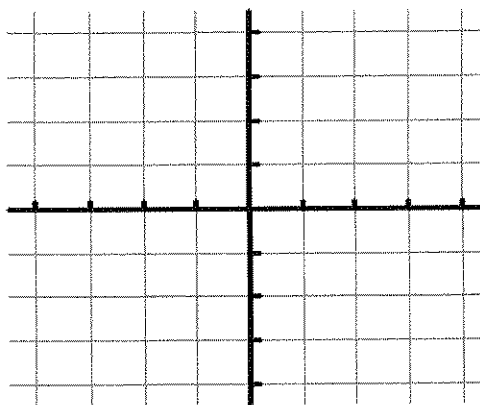
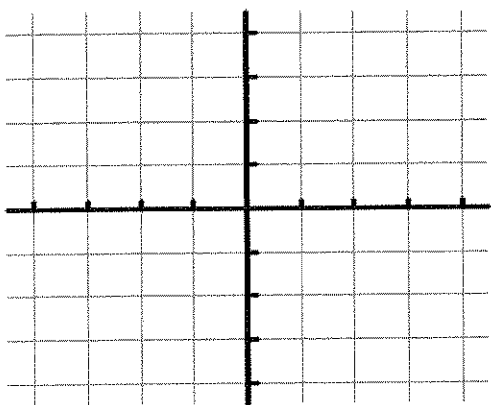

For #5 - 8, match the function to graphs A-D shown below.

5. $y = 3 \sin(2\theta)$

6. $y = 3 \sin(1/2\theta)$

7. $y = -3 \sin(1/2\theta)$

8. $y = -3 \sin(2\theta)$

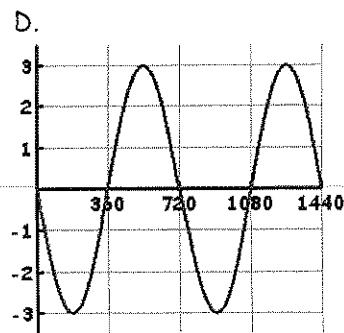
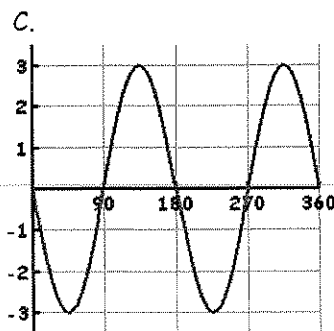
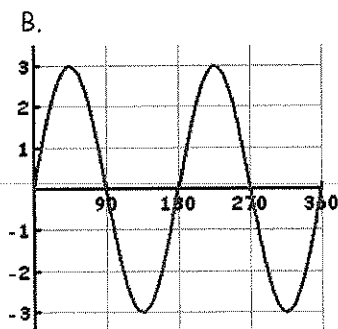
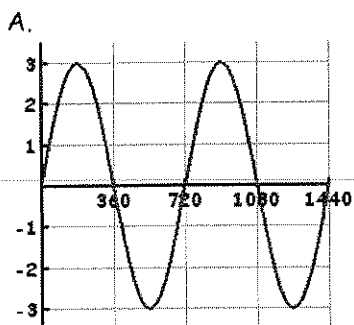

Write the equation for the following trigonometric functions.

9. In physics class, Eva noticed the pattern shown in the accompanying diagram on an oscilloscope.

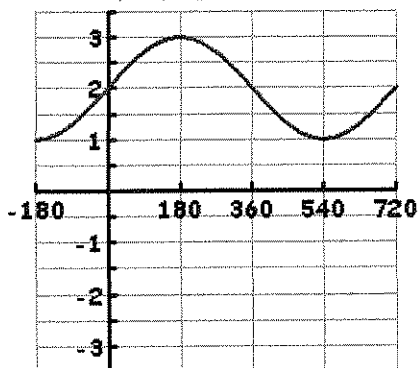

10.

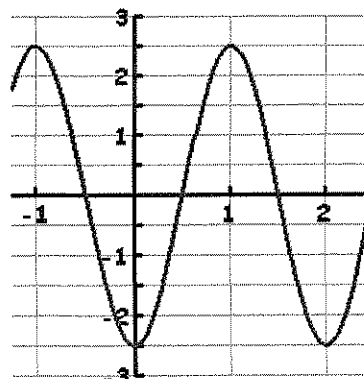

11.

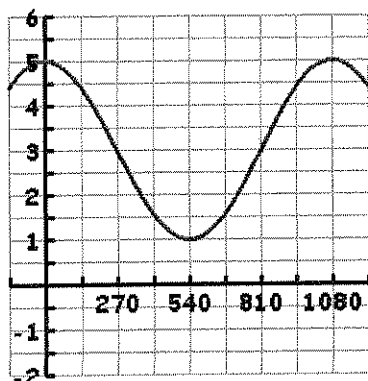

12.

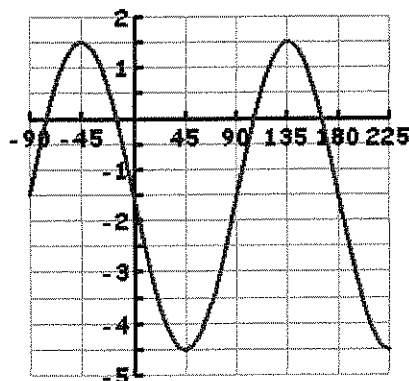

Given the following information about a trig function, write an equation for each.

13. a sine function with amplitude = $\frac{1}{2}$, period = 60° , and a vertical shift 4 down

14. a cosine function with amplitude 7, period 540° , a reflection over the x-axis, and vertical shift 1.5 up

Homework Day 14 Test Review

1. Find the remaining sides and angle in the following triangle.

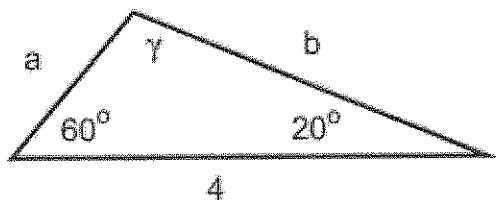

2. Find the third side of the following triangle:

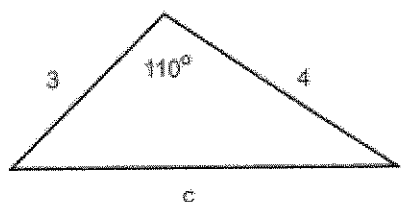

3. For the function $y = -5 + 4\cos(3x)$, find
- The amplitude.
 - The period.
 - The equation of the midline.
 - Graph 1 period in the negative and positive directions.

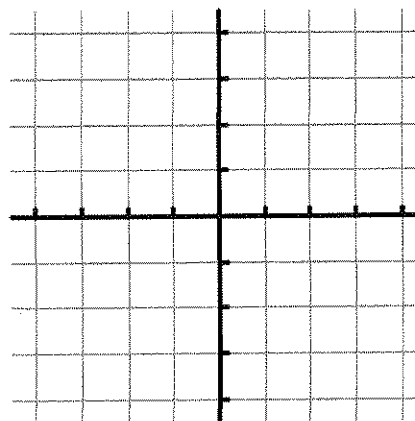

4. A building 180 feet tall casts a 90 foot long shadow. If a person looks down from the top of the building, what is the measure of the angle of depression? (Assume the person's eyes are level with the top of the building.)

5. Solve the right triangle. Find sides and angles in degrees to at least 3 decimal places.

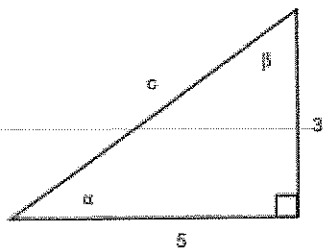

6.

A. Find $\cos \theta$

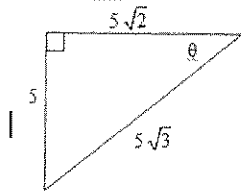

B. Find $\sin \theta$

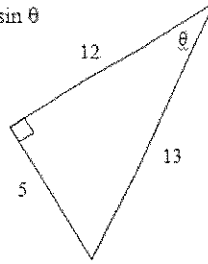

C. Find $\tan \theta$

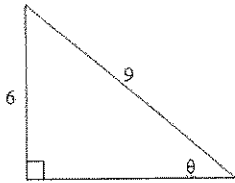

D. Find $\sin \theta$

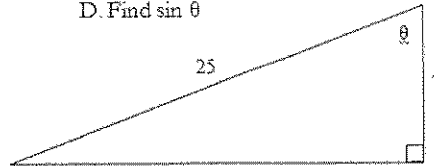

7. A person is standing 30 meters from a traffic light. If the angle of elevation from the person's feet to the top of the traffic light is 25 degrees, find the height of the traffic light.

8. Find all solutions to $2\sin 2x + 1 = 0$ for $0 \leq x \leq 360$.

9. From the top of a fence, a person sites a lion on the ground at an angle of depression of 24 degrees. If the man and the fence is 4.2 meters high, how far is the man from the lion?

10. Find the measure of angle A, to the nearest degree, if $\sin A = .9659258$.

11. A ship leaves port at 1 pm traveling north at the speed of 30 miles/hour. At 3 pm, the ship adjusts its course on a bearing of N 20° E. How far is the ship from the port at 4 pm?

12. Find the approximate value of $\tan 735$.

13. Solve the right triangle.

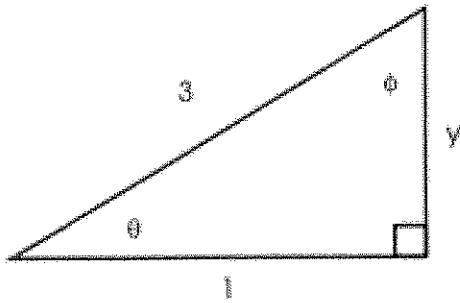

14. Find the area of the triangle. If necessary, round the answer to two decimal places.

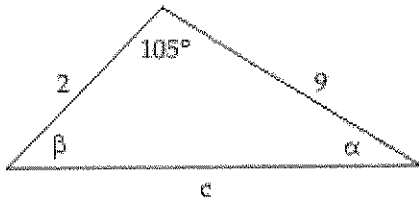

A) 2.33

B) 8.69

C) 101.42

D) 34.77

15. In the diagram below, find the approximate value of each part labeled with a variable. Show all work.

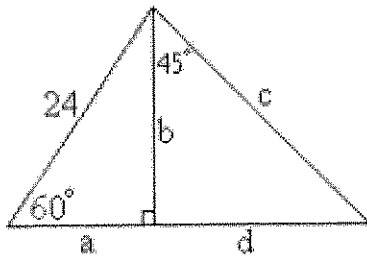

16. Classify each triangle by its sides and its angles:

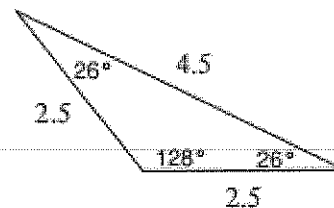
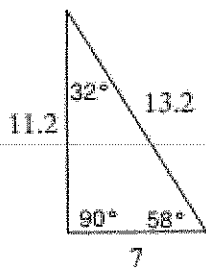
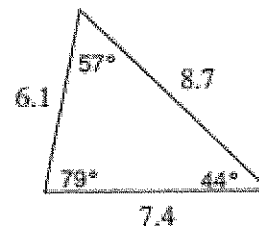
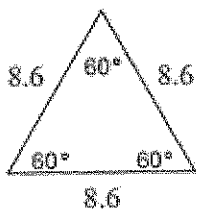

17. Given $y = 3 \sin(2x)$

- a. Find the midline.
- b. Find the amplitude.
- c. Find the period.
- d. Graph one cycle

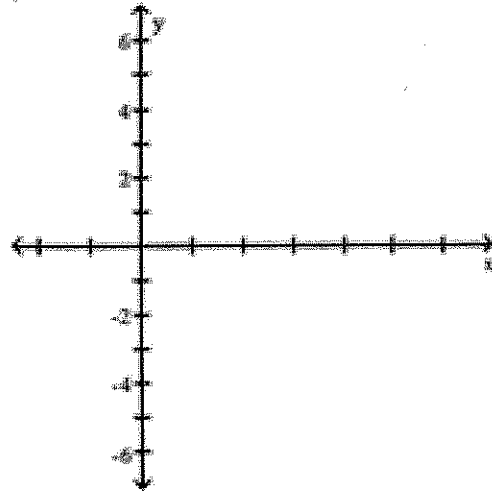

Solve the following trigonometric equations.

18. $\sin x \cos x \tan x + \sin x \cos x = 0$

19. $2\cos x(\cos x + \frac{1}{2}) = 0$

20. $2\cos x + 1 = 2$

21. Find $\sin(15)$ and $\cos(75)$. Why is there something special about their values?

Solve the following triangles. Round angles to the nearest degree and sides to the tenths place.

22. $a = 30, b = 40, A = 20^\circ$

23. $a = 3, b = 9, c = 8$